



**BLUE LOGIC**

## OPERATION AND MAINTENANCE MANUAL

DOCUMENT TITLE: Operation and Maintenance Manual Ø55 Valve Stab System  
PROJECT TITLE: Ø55-Valvestab  
PROJECT: 600112  
DOCUMENT NUMBER: 600112-TD-0003  
REV: 07  
NUMBER OF PAGES: 34

DATE: 15.08.2022  
CLIENT: Blue Logic AS  
CONTACT PERSON: Lars Gunnar Hodnefjell





# OPERATION AND MAINTENANCE MANUAL

## OBJECTIVE

The objective of this document is to present a comprehensive Operation and Maintenance manual for the Blue Logic designed Ø55mm **Valve Stab™** System. All relevant aspects with regards to safe and correct use, installation, operation, maintenance and storage are covered.

## ABSTRACT

The Blue Logic **Valve Stab™** System combines the functionality and quality of a ball valve and a pressure balanced Hot Stab thus forming a reliable field proven leakage free high flow ROV Stab Connector System. The Blue Logic **Valve Stab™** System Program comprises a variety of sizes configurations and versions. This document includes all Valve Stab products in the Ø55 program except for the special designed Ø55 Hexa Port Valve Stab System with integrated "clean connection" flushing capabilities. The Ø55 Valve Stab program includes the following general main components:

- Male **Valve Stab™** (different number of ports and versions available)
- Female **Valve Stab™** Receptacle
- Fail Safe Close/Open System
- Cavity flushing system
- Protection Stab
- Parking receptacle

In general, the **Valve Stab™** System is connected and operated as a standard API/ ISO pressure balanced Hot Stab system. The stab is simply pushed into the receptacle to connect and pulled out to disconnect. The main difference between the **Valve Stab™** and the standard Hot Stab with regards to operation is that the **Valve Stab™** must be inserted into receptacle with correct alignment. After insertion, the valve function is easy operated by use of the manipulator thus locking the stab into the receptacle for increased safety and control during operation.

All operation is performed directly by use of a Standard ROV manipulator.

## REVISION CHANGE/RECORD

REV	REASON FOR REVISION/ DESCRIPTION OF CHANGES
01	First revision issued for use
02	General Update. New Mating-indicator manual added.
03	Added info on seal change on receptacle
04	CP protection & preservation/storage
05	Added chapter 2.1.2 Pressure Stab
07	Added info regarding pairing receptacle and stab with different number of ports not possible. Maintenance section updated.



TABLE OF CONTENT

- 1. INTRODUCTION ..... 5
  - 1.1. DOCUMENT USE..... 5
  - 1.2. ABBREVIATIONS..... 5
- 2. TECHNICAL DESCRIPTION..... 6
  - 2.1. GENERAL..... 6
    - 2.1.1. Stab..... 7
    - 2.1.2. Ports..... 15
    - 2.1.3. Pressure Stab..... 16
    - 2.1.4. Receptacle..... 17
    - 2.1.5. Optional Connection Flushing System..... 21
    - 2.1.6. Optional Weak Link..... 23
- 3. INSTALLATION..... 24
  - 3.1. RECEPTACLE ..... 24
    - 3.1.1. Mechanical installation..... 24
    - 3.1.2. Hydraulic installation..... 24
  - 3.2. STAB..... 24
    - 3.2.1. Hydraulic connection..... 24
- 4. PREPARATION FOR USE ..... 25
  - 4.1. ONSHORE PREPARATIONS ..... 25
    - 4.1.1. Mobilisation Check List..... 25
- 5. OPERATION ..... 26
  - 5.1. OFFSHORE PREPARATIONS ..... 26
  - 5.2. PRE-DIVE CHECK..... 26
    - 5.2.1. Stab Pre-Dive Check List ..... 26
    - 5.2.2. Receptacle Pre-Dive Check List ..... 27
  - 5.3. SUBSEA CONNECTION..... 27
  - 5.4. SUBSEA DISCONNECTION ..... 30
  - 5.5. POST DIVE CHECK ..... 31
- 6. MAINTENANCE ..... 31
  - 6.1. GENERAL..... 31
  - 6.2. WEEKLY MAINTENANCE..... 32
  - 6.3. MONTHLY MAINTENANCE..... 32
  - 6.4. YEARLY MAINTENANCE..... 33
  - 6.5. SEAL REPLACEMENT..... 33
    - 6.5.1. Main Outer Seal (Stab) ..... 33

## OPERATION AND MAINTENANCE MANUAL

7.	STORAGE AND TRANSPORT .....	34
7.1.	STORAGE .....	34
7.1.1.	Preservation for Storage .....	34
7.2.	TRANSPORT .....	34



# OPERATION AND MAINTENANCE MANUAL

## 1. INTRODUCTION

The Blue Logic **Valve Stab™** is a patented hydraulic connector system combining technology from standard Hot Stab connectors and Ball Valves into a very compact and lightweight subsea connector system. The unique features obtained allows for 100% leakage free subsea connection with full system pressure. Since the system includes built-in valve functionality both in the stab and receptacle side, subsea valve and connector panels can be designed extremely compact compared to alternative solutions.

The **Valve Stab™** technology is relevant for use in almost all subsea connector applications and can be easily operated by use of either Diver or ROV. The System is fully pressure balanced and does not introduce any axial forces into the connector or panel system. When the system is connected and the ports are opened, the Stab Connector is locked into the receptacle system automatically.

Despite all included functions, the Valve Stab™ System is a very simple and robust construction with very few moving parts. All seals can easily be replaced offshore.

### 1.1. DOCUMENT USE

This document shall be used as general information for all aspects related to safe use, installation, removal, maintenance and storage of the **Valve Stab™** System. Included in this Operation and Maintenance Manual are sequential step-by-step procedures for typical offshore operations which can be used for establishing detailed specialized offshore/subsea procedures. These lists can also be used for documentation of performed work and sequences if required.

The **Valve Stab™** System includes different sizes, variants and configurations, this document covers Operation and Maintenance of the Ø55mm Blue Logic Valve Stab™ program. Additional manuals are however also available for special variants or client/ project specific designs.

### 1.2. ABBREVIATIONS

ROV:	Remotely Operated Vehicle
HPU:	Hydraulic Power Unit
FAT:	Factory Acceptance Test
MOB:	Mobilisation
DEMOB:	Demobilisation

## 2. TECHNICAL DESCRIPTION

### 2.1. GENERAL

The Ø55 Valve Stab™ program includes versions ranging from 1-6 hydraulic ports. The system is also available in other sizes and with other port configurations. Dedicated technical documentation is available for different sizes and configurations although all Valve Stab™ Systems are based on the same core technology and will be operated using the same principles.

It is the responsibility of the end user to make sure that the product is used in such a manner for which it is designed. This includes accounting for material/fluid compatibility, sour service, temperature, pressure rating etc. Refer to specific product drawing which includes all relevant information. If product drawing is lacking information/unclear contact Blue Logic.

#### Caution!

Please note that a stab can only be mated with a receptacle with corresponding number of ports, i.e. a dual port stab can only be mated with a dual port receptacle. Distance between ports are different for the 1-6 port types. Mating of stab and receptacle with different number of ports may cause injuries, damages to equipment and spill of fluid.

2.1.1. Stab

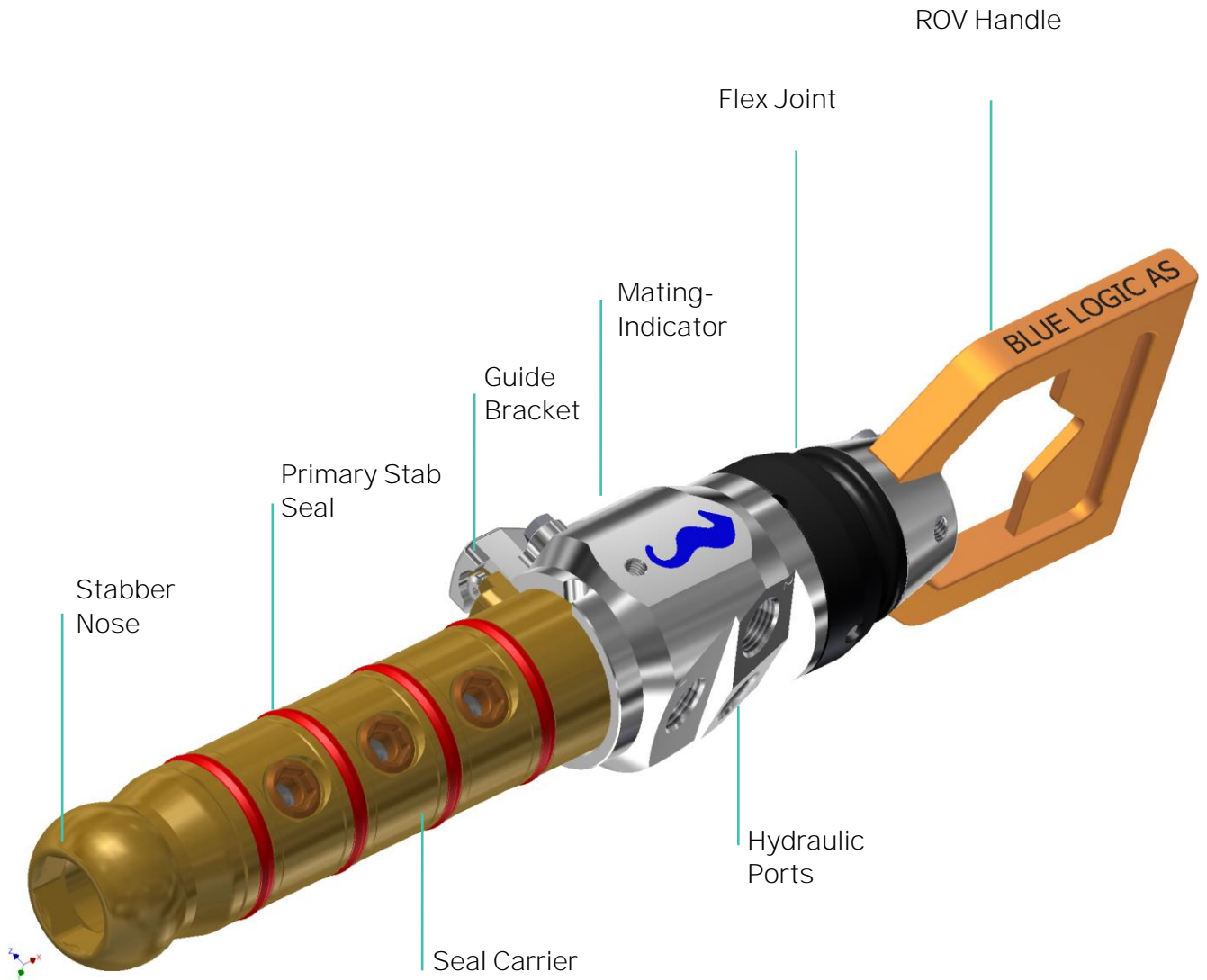

Figure 1 Typical Valve Stab™ Main Parts



2.1.1.1. *Mating-Indicator.*

The purpose of the Valve Stab™ Mating-Indicator is to visually confirm correct mating of the Valve Stab™ into the Receptacle prior to flushing of cavities or operation of the Valve Stab™ Valve function.

*OBS! The Mating-Indicator is produced in two different versions: V1.0 and V2.0. Please, note which version you possess, and proceed to correct chapter.*

*V1.0 - (Indicator Pin)*

V1.0 Indicator installed on Valve Stab™ produced prior to 2013/2014.  
Chapter 2.1.1.2

*V2.0 - (Aligning Red Lines)*

V2.0 Indicator installed on Valve Stab™  
Chapter 2.1.1.3

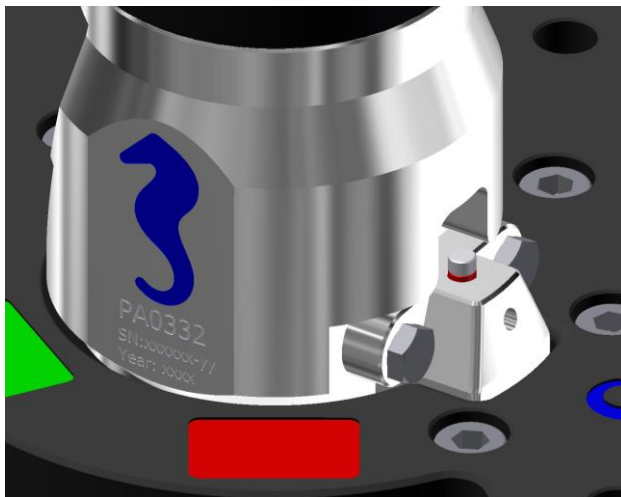

*V1.0 Indicator Pin*

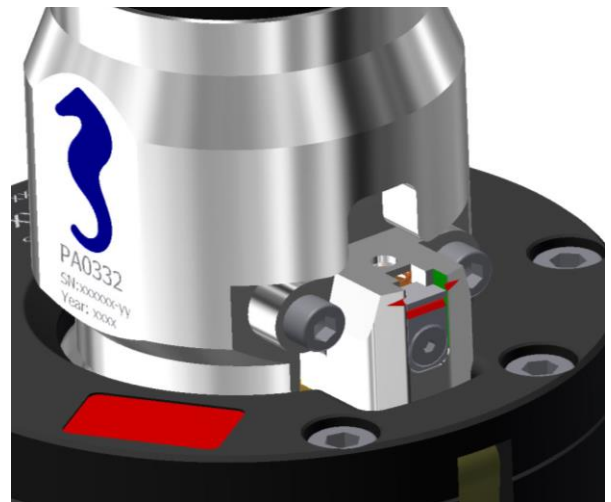

*V2.0 Aligning Red Lines*



2.1.1.2. V1.0 Indicator Pin

The Indicator pin is white and will pop out approx. 4mm when the Stab is correctly mated as illustrated on below figures. When the red colour appears, the Stab is fully mated into the receptacle and ready for operation.

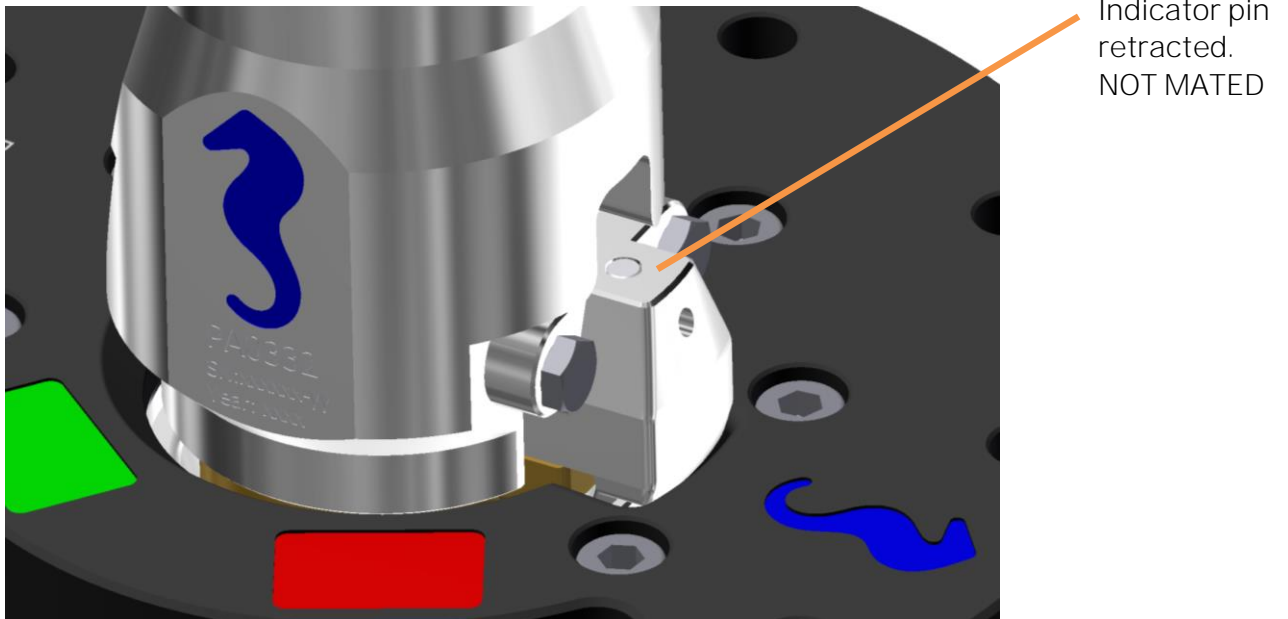

Figure 2 Stab prior to docking into Receptacle

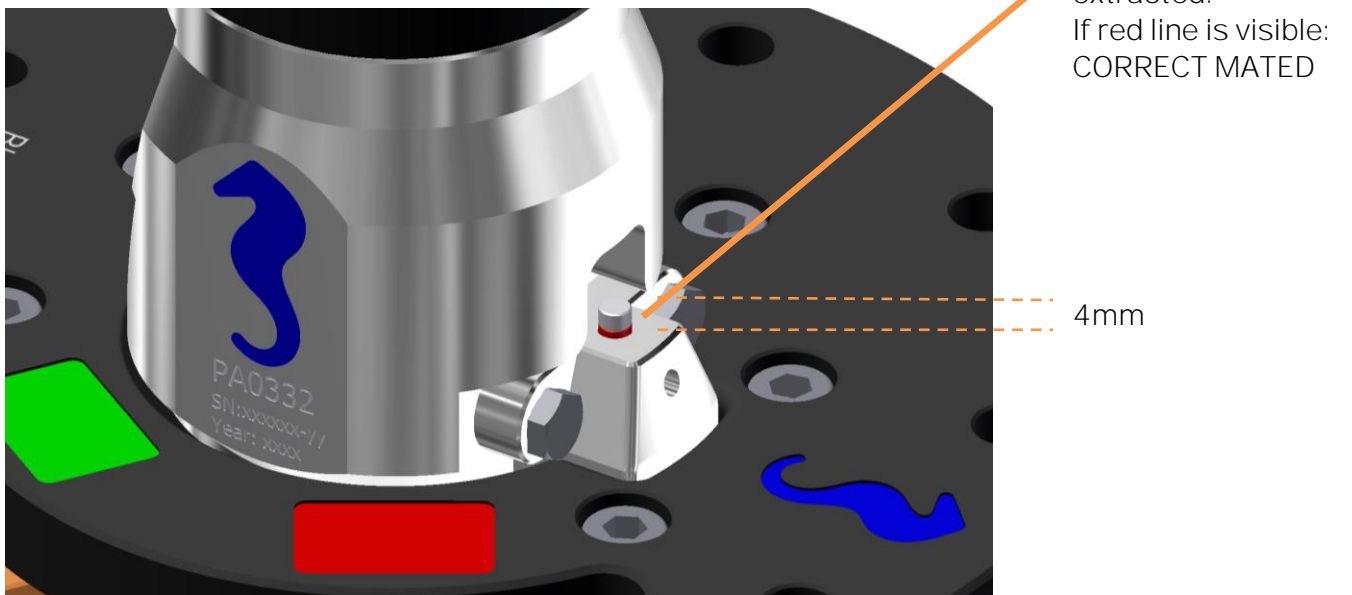

Figure 3 Stab correct mated into Receptacle

2.1.1.3. V2.0 Aligning Red Lines

The Mating-Indicator consists of a set of Red Lines, as illustrated on the figures below. The Stab is correctly mated with the receptacle and ready for operation when the Red Lines in the Mating-indicator aligns.

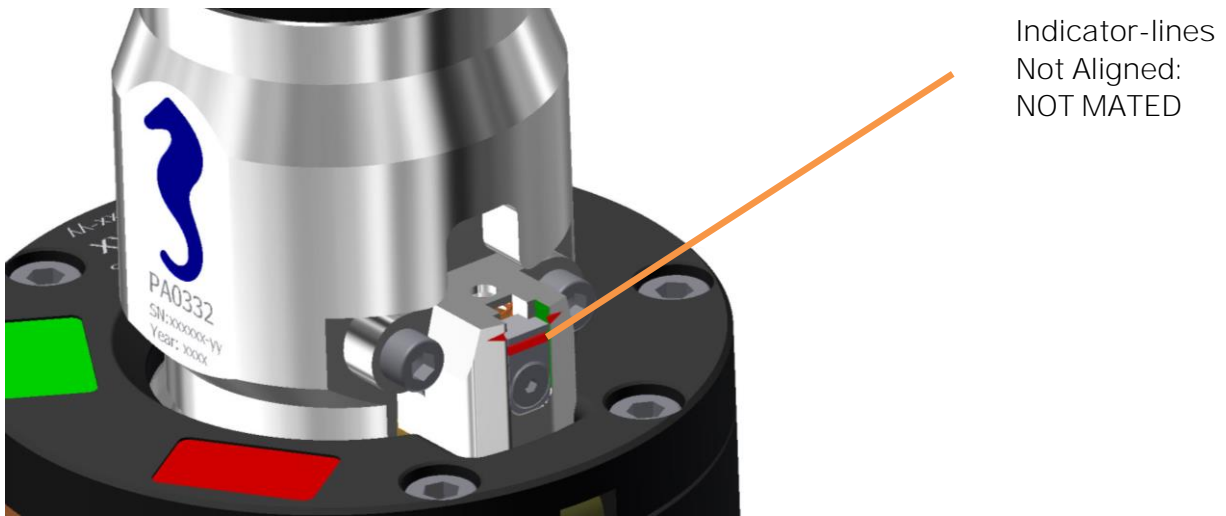

Figure 4 Stab prior to docking into Receptacle

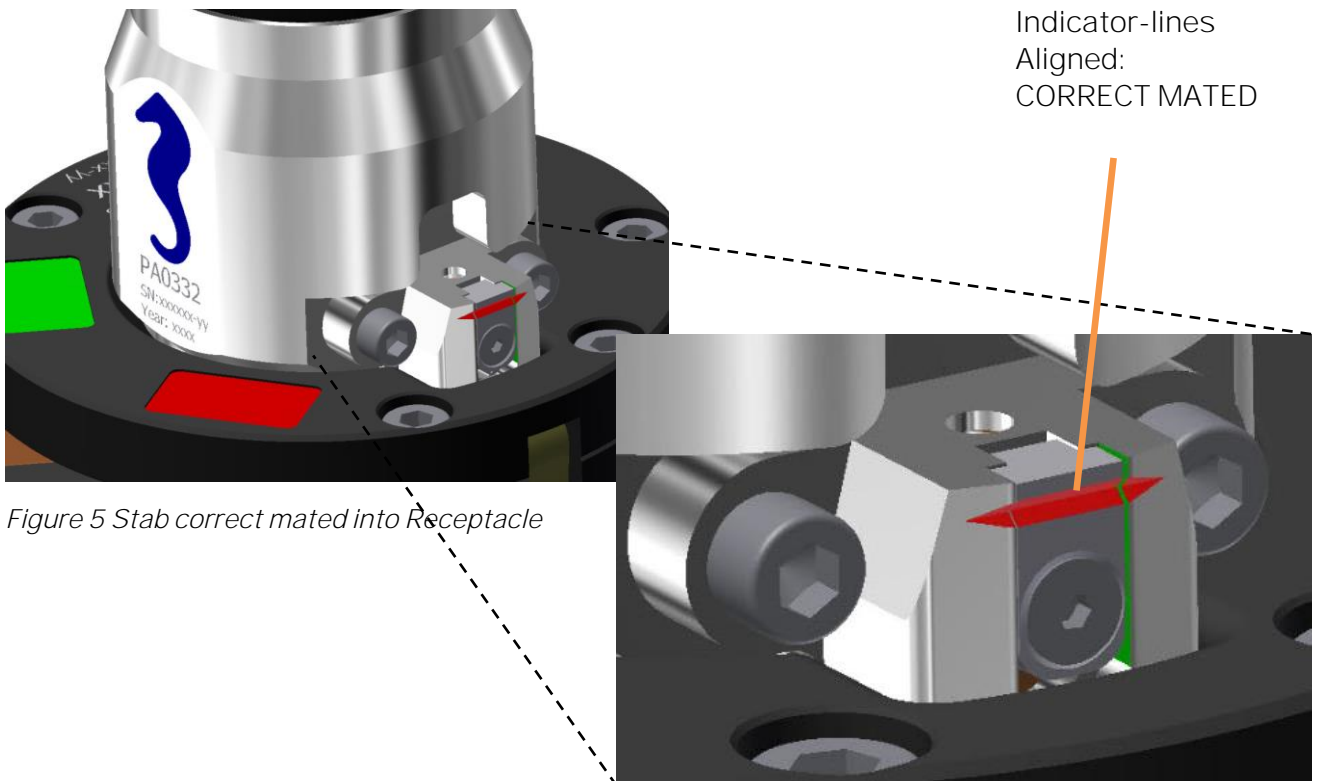

Figure 5 Stab correct mated into Receptacle



#### 2.1.1.4. Stabber Nose

The Stabber Nose secures correct and gentle guiding of the Stab into the Receptacle. It is constructed by use of an Aluminum Bronze alloy to protect the receptacle internals. The Stabber nose is connected to the Stabber by use of threads and can be unscrewed by use of a Hex umbraco tool. Stab nose Hex key size is 30mm. The Stabber Nose secures and locks the Seal Carrier onto the Stab.

#### 2.1.1.5. Primary Stab Seal

The Primary Stab Seals separates the different hydraulic ports and seals toward the receptacle. Different alternative seal profiles and materials are available depending on application and fluid. Standard Blue Logic seal material is HPUR, which is compatible with most relevant fluids and have mechanical ensuring long service life without need for replacement. The Primary Stab Seals can however easily be replaced offshore without need for any disassembly of the stab. Please see following sections for details with regards to seal replacement.

#### 2.1.1.6. Seal Carrier

All stabber seals are placed in the Valve Stab™, both the internal Core Seals and the outer Primary Seals. The Seal Carrier is replaced by unscrewing the stabber nose and seal cartridges. Note: Seal cartridge are secured with Loctite 577 and needs to be heated to approx. 80-100 deg before unscrewing. Use hot water or air gun to heat. (If air gun is used, never heat directly on seals)



Figure 4 Valve Stab™ Seal Carrier with internal and external seals (typical Valve Stab design)

### 2.1.1.7. Seal Cartridges

The Seal Cartridges includes the Spherical Core Seal which seals toward the Valve Stab™ Core placed inside the Seal Carrier. The Seal Cartridges can be unscrewed by use of a 12mm Hex Umbraco key for replacement or inspection. Please see section for maintenance with regards to replacement of seal or seal systems.

Note: Seal cartridge are secured with Loctite 577 and needs to be heated to approx. 80-100 deg before unscrewing. Use hot water or air gun to heat. (if air gun is used, never heat directly on seals)

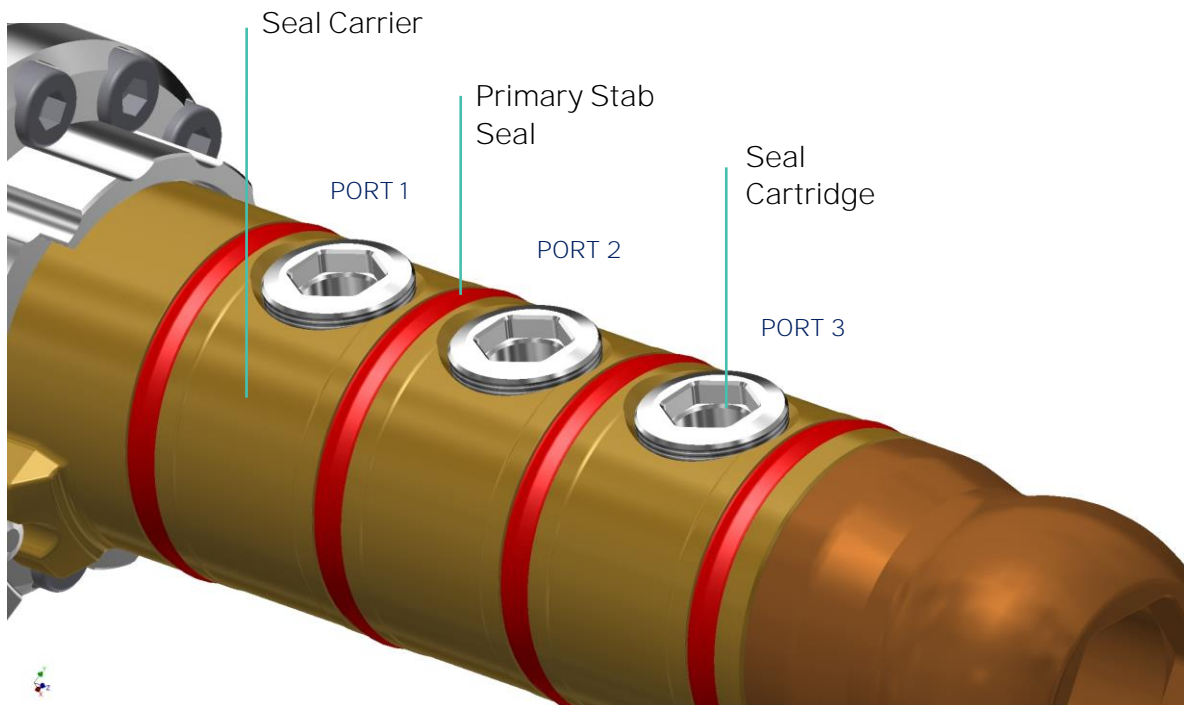

Figure 5 Seal Carrier and Seal Cartridges typical Valve Stab design

Note: on above figure, the Seal cartridges are unscrewed approx 3mm for illustration purposes!

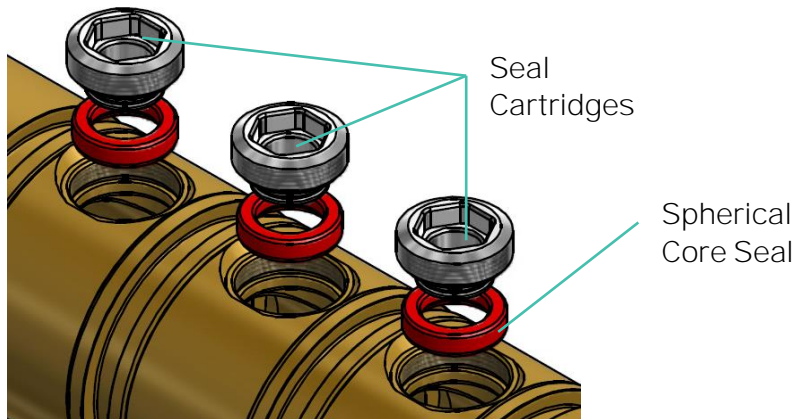

Figure 6 Seal Cartridges removed

### 2.1.1.8. Hydraulic Ports

The Ø55 Valve stab is delivered with different port interfaces. See datasheets or product Assembly drawings for details with hydraulic connections and ports.

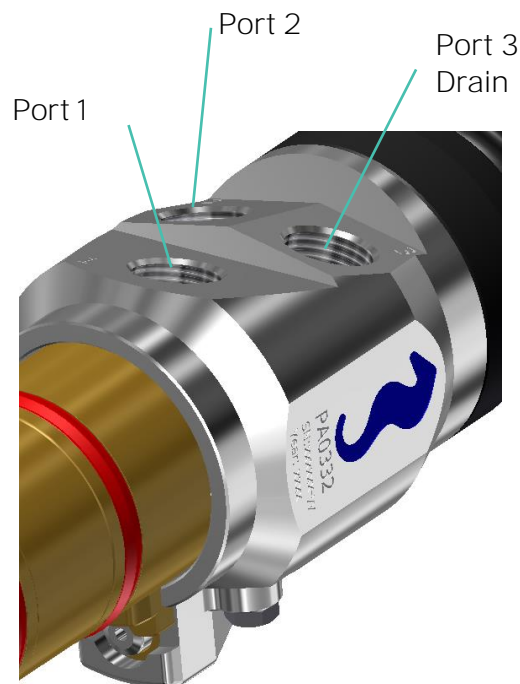

Figure 7 Valve Stab Hydraulic Interface

For BSP port variants, Blue Logic recommends to use Dowty seal rings on the fittings to be used for both Valve Stab™ and Valve Stab™ Receptacle connections.



*2.1.1.9. Flex Joint*

The Flex Joint connects the Valve Stab™ body to the ROV Handle. It consists of an outer flexible element and an inner mechanical connection. The Flex Joint allows for a smooth angle deviation of approx 20 degrees in all directions between the ROV handle and Valve Stab™. The flex element can easily be replaced, see maintenance section for details with regards to replacement of flex element.

*2.1.1.10. ROV Handle*

The Valve Stab™ can be delivered with different alternative ROV Handles. Most common is the ROV "D-Handle". ROV Handles can easily be replaced by unscrewing the ROV Handle bolts.

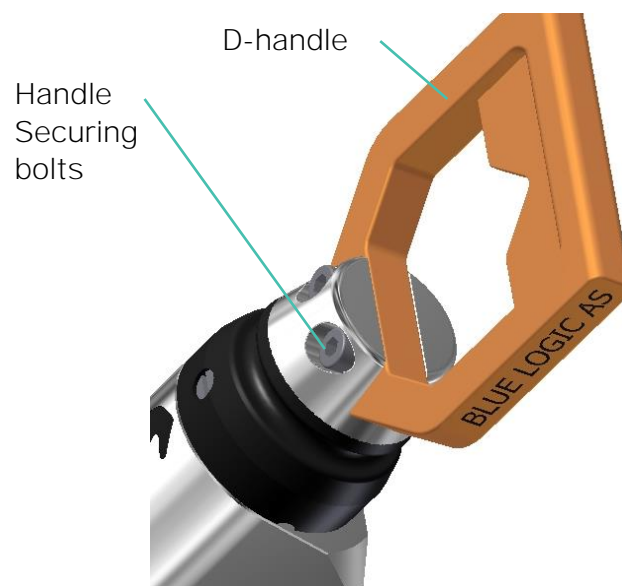

*Figure 8 ROV Interface*

*2.1.1.11. Guide Bracket*

The Guide Bracket ensures that the Valve Stab™ is aligned correctly prior to connection into the Receptacle. The Guide Bracket fit's into the machined Orientation Groove in the receptacle and once correct inserted triggers the receptacle position lock system.

### 2.1.2. Ports

The ports come in various configurations, see data sheet for specific connection.

For all stabs, (independent on number of ports) port 1 is defined as the upper most port.

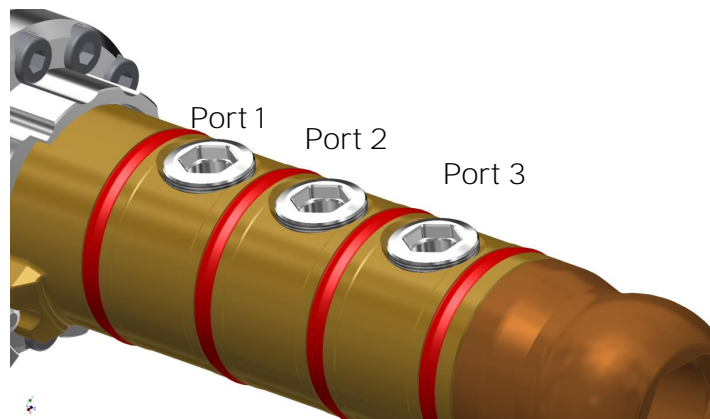



## OPERATION AND MAINTENANCE MANUAL

### 2.1.3. Pressure Stab

The  $\varnothing 55$  Pressure Stab is capable of holding full working pressure. The pressure stab is easily operated by simply stabbing it into the receptacle and is orientation independent.

When used in a Valve Stab System the primary function of the pressure stab is to act as a second barrier. The receptacle acts as the first barrier and shall in principle hold the pressure on its own.



*Figure 9:  $\varnothing 55$  Pressure Stab*





## OPERATION AND MAINTENANCE MANUAL

### 2.1.4. Receptacle

The Valve Stab™ receptacle consists of the following main parts;

1. Outer Housing
2. Inner Center Core
3. ROV/Diver Handle
4. Seal Cartridges
5. Internal seals
6. Bracket/ securing interface
7. Orientation Groove
8. Hydraulic Ports
9. Receptacle Top Plate

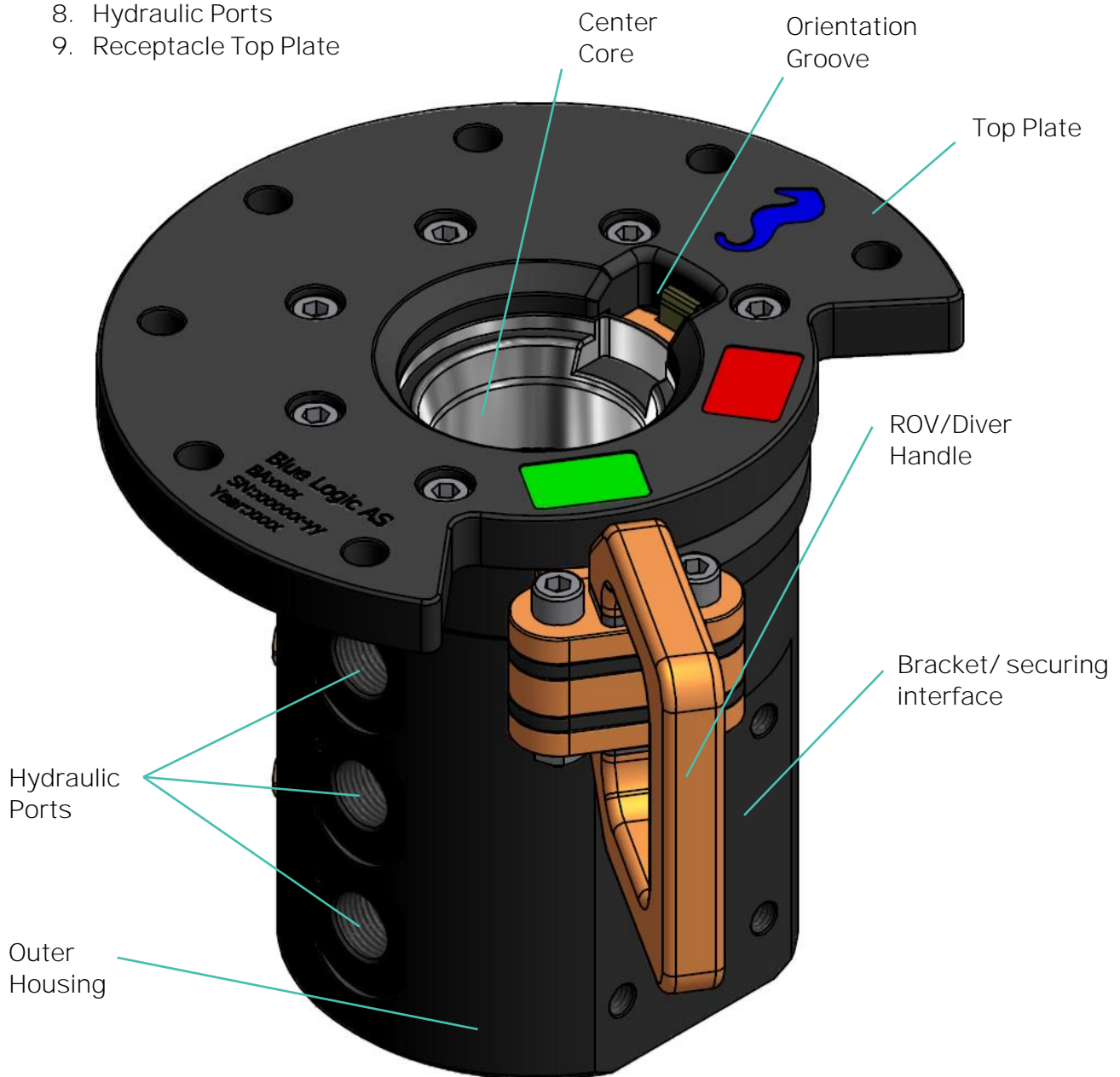

Figure 10 Valve Stab Receptacle



## OPERATION AND MAINTENANCE MANUAL

### *2.1.4.1. Outer Housing*

The Outer Housing includes the hydraulic ports, interface for installation (securing interface) and interface for seal cartridges as further described in following sections. All **Valve Stab™** receptacle seals are placed inside the Outer Housing.

### *2.1.4.2. Center Core*

The Inner Center Core rotates inside the Outer Housing thus opening and closing the hydraulic ports. It is constructed by corrosion resistant high strength alloy to reduce wear and improve lifetime.

### *2.1.4.3. Seal Cartridges*

Similar as for the male **Valve Stab™**, the Seal Cartridges contains the Spherical Cores Seals which seals towards the Inner Centre Core. A standard 3-port **Valve Stab™** System includes 6 off Seal Cartridges in the receptacle.

The Seal Cartridges is secured by use of Loctite 577 and can be unscrewed by use of a standard 13mm hex head.

### *2.1.4.4. ROV/Diver Handle*

The ROV handle operates the **Valve Stab™** Open/Close function. It is to be rotated 65 degrees in order to operate the **Valve Stab™**.

Operate ROV Handle Clockwise (green area)

- The **Valve Stab™** valve functions are CLOSED and the stab can be inserted or retracted from the receptacle

Operate ROV Handle Counter Clockwise (red area, "Hot")

- The **Valve Stab™** valve functions are OPEN and the stab is LOCKED in position into the receptacle.

NOTE:

The **Valve Stab™** must be correct and fully inserted into the **Valve Stab™** Receptacle in order to OPEN the **Valve Stab™** valve functions. Not possible to open before.

### *2.1.4.5. Internal seals*

**Valve Stab™** receptacle internal seals are not shown on above figure. The seals are placed on the inner side of the outer housing. The Center Core will need to be removed from the outer housing in order to replace the internal seals.

2.1.4.6. Bracket/ securing interface

The Bracket Securing interface is used to securing the Receptacle onto the ROV or subsea equipment. See product assembly drawings for interface details.

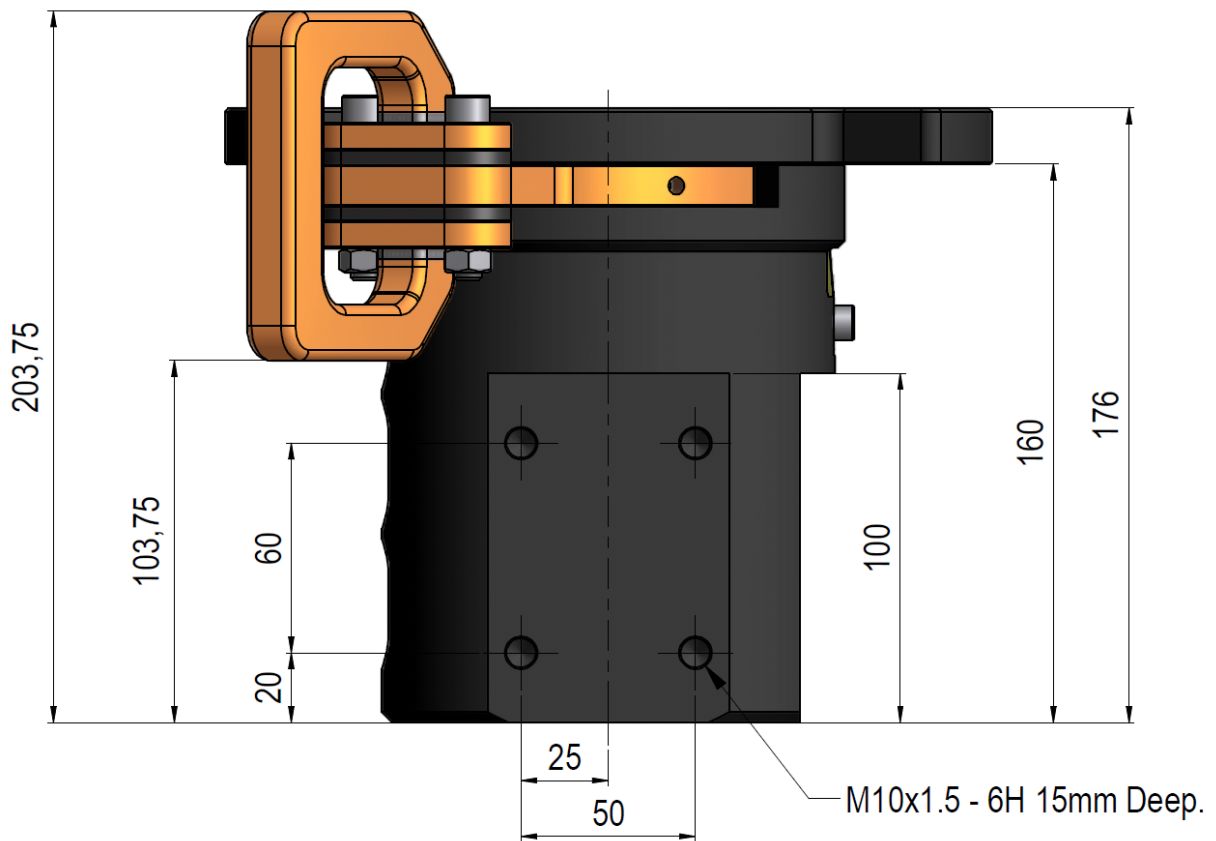

Figure 11 Bracket Securing Interface example (3-port version)

#### 2.1.4.7. Orientation Groove

The Orientation Groove in the Receptacle ensures correct orientation of the Valve Stab™ when inserting into the receptacle. When the Valve Stab™ is fully inserted into the Receptacle, the Valve Stab™ Guide Bracket activates a Lock Spring in the Orientation Groove thus allowing for operation of the Valve Stab™ and Receptacle Valve Mechanism.

#### 2.1.4.8. Hydraulic Ports Receptacle

See Product Assembly drawings or datasheets for hydraulic port details.

#### 2.1.4.9. Receptacle Top Plate

The Receptacle Top Plate is bolted onto the Receptacle outer housing. It includes the Orientation Groove and color marking for Valve Stab™ Valve position.



Figure 12 Valve Stab™ and receptacle mating



## OPERATION AND MAINTENANCE MANUAL

### 2.1.5. Optional Connection Flushing System

One of the unique features with the Valve Stab™ System is the ability to perform a 100% clean subsea multiport connection. The Ø55mm Valve Stab™ design results in only 7ml entrapped volume for each port during connection. This cavity volume can be flushed prior to opening the Valve Stab™ ports. There are different ways of performing this flushing process depending on the Stab/Receptacle configuration. Blue Logic has developed optional special equipment to effectively perform this flushing process.

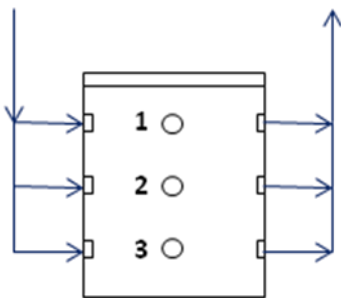

Figure 13 Alternative 1 Flushing principle

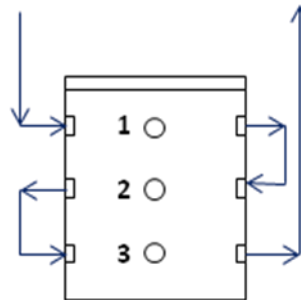

Figure 14 Alternative 2 Flushing principle

In general, the flushing shall be performed by flushing through the receptacle flushing ports prior to operation of the Valve Stab™ function.

#### 2.1.5.1. Flushing using Hydraulic Supply Directly from ROV

This alternative is most relevant when the Receptacle is installed on the ROV. By use of the ROV hydraulic system, a dirty work package or the Blue Logic special designed Flushing Unit, clean fluid is flushed through the receptacle and stab cavities after the stab is inserted into the receptacle, but before the Valve mechanism is opened. In general, flushing according to Alternative 1 should be performed by use of the Blue Logic special designed Flushing Unit to ensure that all stab ports are flushed equally. If a standard Dirty Valvepack or the ROV hydraulic system is used directly for flushing, Alternative 2 as shown on above figure 6 is recommended.

#### 2.1.5.2. Flushing using Blue Logic Valve Stab™ Flushing Unit

The special designed Blue Logic Flushing Unit is designed for easy and effective flushing of the Valve Stab™ cavities prior to opening the Valve Stab™ Valve Function. The unit consists of 3 relatively small pistons which are connected to the Valve Stab™ flushing ports through a manifold system including check valves. By operating the unit, fluid is flushed through each cavity volume respectively. The Flushing Unit can be connected to a remote reservoir or a small local reservoir on the Flushing Unit.

The Flushing unit can be operated hydraulic or mechanically by Diver or the ROV manipulator.

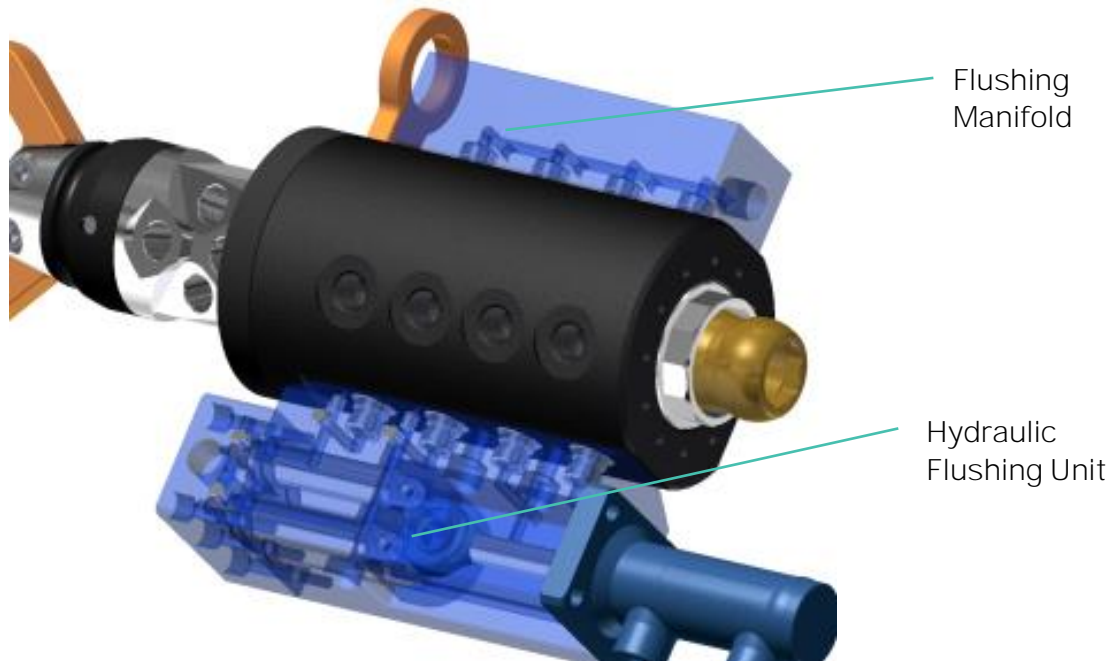

Figure 15 Hydraulic operated Valve Stab™ Cavity Flushing Unit, principle drawing

#### 2.1.5.3. Flushing of cavity using Valve Stab™ flushing lines

In configurations where the receptacle is placed on the module, structure or tool, flushing of Valve Stab™ cavities will require supply of flushing fluid. Blue Logic has designed a system for flushing of Valve Stab™ cavities on such "remote" receptacles through dedicated hydraulic ports in the stab system. Please contact Blue Logic for further details.



### 2.1.6. Optional Weak Link

A weak link ring can be bolted to the receptacle top plate. The weak link ring is made in a polymer material designed to fail at pulling forces of approximately 300kg.

Once the Valve Stab has been mated with the receptacle, the system can be set in the opened position. By setting the system in the opened position, the Valve Stab guide bracket will rotate under the weak link ring.

Should the Valve Stab experience excessive pulling forces, the guide bracket will pull the weak link off the receptacle.

If the Valve Stab and weak link are pulled off, the receptacle/stab will leak fluids to the surroundings.

The receptacle must be recovered to the surface and the weak link must be replaced to be able to operate the receptacle again.

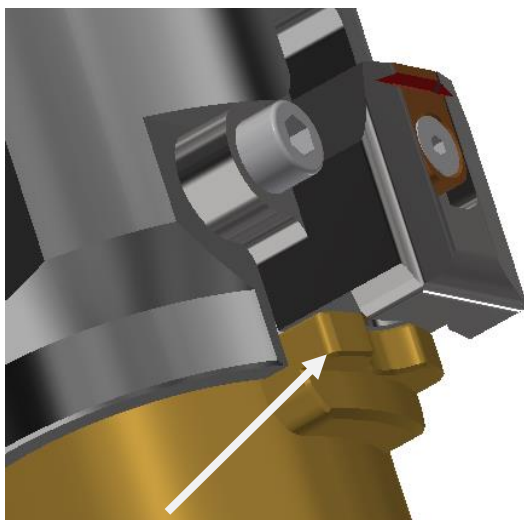

Guide Bracket

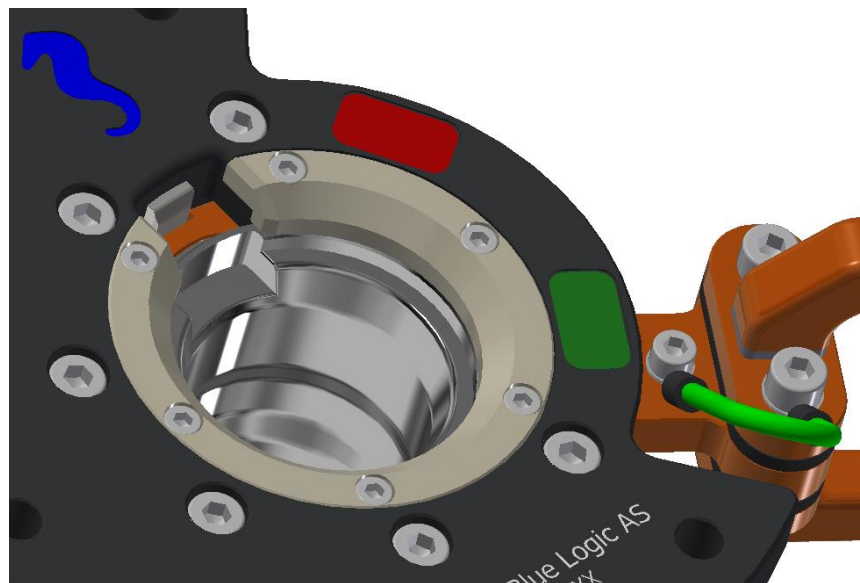

### 3. INSTALLATION

#### Caution!

ValveStabs and Receptacles cannot be interchanged, i.e. stab and receptacle must have same number of ports. Risk of injuries and/or damage to equipment if mating stab and receptacle with different number of ports.

#### 3.1. RECEPTACLE

In general, Blue Logic recommend installing a Valve Stab™ Receptacle both on the supplier (typical the ROV/ROT) and on the consumer (tool, structure etc). This allows for using separate hydraulic jumpers which can easily be replaced subsea in case of damages without the need for recovery of ROV or tools. This ability is achieved due to the excellent flow performance in the system.

##### 3.1.1. Mechanical installation

The Receptacle shall be secured and bolted onto the ROV/structure/tool directly by use of the integrated installation interface as described in above Section 2.1.4.6. Blue Logic recommend installing the receptacle vertically. This will ease guidance of the stab. Any debris or dirt will then fall through the receptacle.

##### *3.1.1.1. CP protection*

All intervention Valve Stab receptacles must have sufficient CP. When installing receptacles resistance should be measured to verify that there is connection. If necessary, separate cable for grounding can be used. Outer housing of intervention receptacles is made of hard-anodized aluminum, this must be taken in consideration when choosing anode material.

##### 3.1.2. Hydraulic installation

The hydraulic functions shall be connected to the Receptacle hydraulic ports by use of hoses or piping. Suitable protection plate or similar system for hoses is recommended

#### 3.2. STAB

##### 3.2.1. Hydraulic connection

Hydraulic connection to the receptacle is performed by use of standard hydraulic BSP fittings. Recommended seal system is Dowty rings.

It is recommended to use hose protection system/wrapping on the hose bundle. Hose strain relief wire can be connected to the dedicated M8 threads by use of a standard eye bolt.





# OPERATION AND MAINTENANCE MANUAL

## 4. PREPARATION FOR USE

### 4.1. ONSHORE PREPARATIONS

Prior to shipping offshore, a mobilisation/ verification should be performed. All functions should be tested and verified. The following check list shall be used as reference for activities to be performed prior to offshore mobilisation:

#### 4.1.1. Mobilisation Check List

No.	Description	Chk/Verified
01	Inspect Stab and receptacle visual	
02	Inspect surface treatment undamaged	
03	Inspect Stab Hydraulic Port Seal areas for damage	
04	Inspect Receptacle Hydraulic port seal areas for damage	
05	Inspect Receptacle seal areas undamaged without scratches	
06	Inspect Stab Guide Bracket undamaged	
07	Inspect Receptacle Orientation groove and verify functionality of the guide/orientation system.	
08	Verify that the stab and receptacle Valve function can not be operated prior to mating. Mate Stab and receptacle.	
09	Verify activated indicator pin on stab (approx 4mm extracted)	
10	Verify that the Valve Stab™ valve function can be operated when connected.	
11	Insert and operated both Stab and receptacle system. Verify smooth and correct movement of Valve function.	
12	Verify that receptacle has sufficient CP protection to structure	
13	Verify that all receptacles have earth cable from centre core to housing (short cable, approx. 5cm)	
14	Verify Correct packing and documentation in the transport box. The transport box should include as a minimum Valve Stab™ system Operation and Maintenance Manual	

5. OPERATION

5.1. OFFSHORE PREPARATIONS

5.2. PRE-DIVE CHECK

Prior to dive, the Valve Stab™ System should be inspected and function tested.

5.2.1. Stab Pre-Dive Check List

No.	Description	Chk/Verified
01	Perform a visual inspection <ul style="list-style-type: none"> <li>- Seals</li> <li>- Seal Areas</li> <li>- Fittings</li> <li>- Hoses</li> <li>- ROV Handle</li> <li>- Flex Joint</li> <li>- Guide Bracket</li> <li>- Hose Tension Relief</li> <li>- Hose conditions, pressure rating, lengths and hose protection</li> </ul>	
02	Verify that the Valve Stab™ is closed and cannot be opened prior to insertion into receptacle	
03	Insert the Valve Stab™ into a Valve Stab™ receptacle, ensure smooth movement and observe friction force.	
04	Open the Valve Stab™ System through the ROV/Diver handle. If a fail safe actuator or similar remote operation mechanism is installed, verify functionality of this.	
05	Close Valve Stab™ and disconnect from receptacle.	
06	Inspect Seals and seal areas.	



# OPERATION AND MAINTENANCE MANUAL

## 5.2.2. Receptacle Pre-Dive Check List

No.	Description	Chk/Verified
01	Visual inspect receptacle internal surface finish and entrance area.	
02	Verify access for ROV and stab into receptacle	
03	Inspect all hoses, piping and fittings for leakage. Pay special attention to seal system.	
04	Verify that the Receptacle valve function cannot be operated when the Male stab is not inserted into the receptacle.	
05	Insert a <b>Valve Stab™</b> into the receptacle. Verify correct installation and access.	
06	Open the <b>Valve Stab™</b> and receptacle valve function by use of the ROV/Diver Handle.	
07	If a fail-safe close system or a remote operation actuator is installed; inspect and verify all functions.	
08	Close Valve function and disconnect <b>Valve Stab™</b> from receptacle	
09	Perform a visual inspection of the receptacle.	

## 5.3. SUBSEA CONNECTION

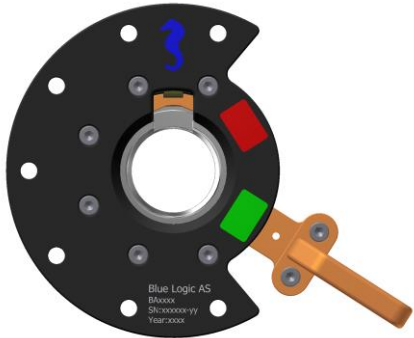
No.	Description	Chk/Verified
01	Visually inspect <b>Valve Stab™</b> Receptacle prior to subsea connection. Verify ROV/ Diver access and general condition of the <b>Valve Stab™</b> Receptacle in front of, and behind the panel.	
02	Inspect <b>Valve Stab™</b> ROV/Diver handle. Verify that the <b>Valve Stab™</b> position is Closed (Green Area) as indicated on figure.  	

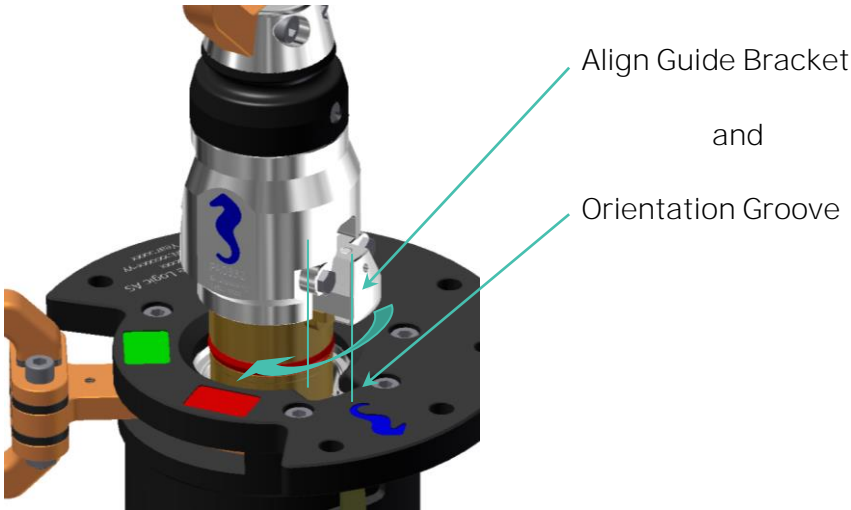

OPERATION AND MAINTENANCE MANUAL

No.	Description	Chk/Verified
03	<p>Start inserting Valve Stab™(use a “loose” grip if possible, align stab into receptacle and gentle slide stab down. Rotate Valve Stab™ in order to align Stab Guide Bracket and Receptacle orientation groove. When correct aligned, push the stab down and fully into the Receptacle. The indicator pin will extract approx 4mm.</p>  <p>Note; For last push it is easier to just push on the top of the D-handle to avoid other forces (bending and rotation forces)</p>	
04	<p>Fully insert the Valve Stab™ into the Receptacle. Ensure correct engagement of Guide Bracket/Orientation Groove.</p>	

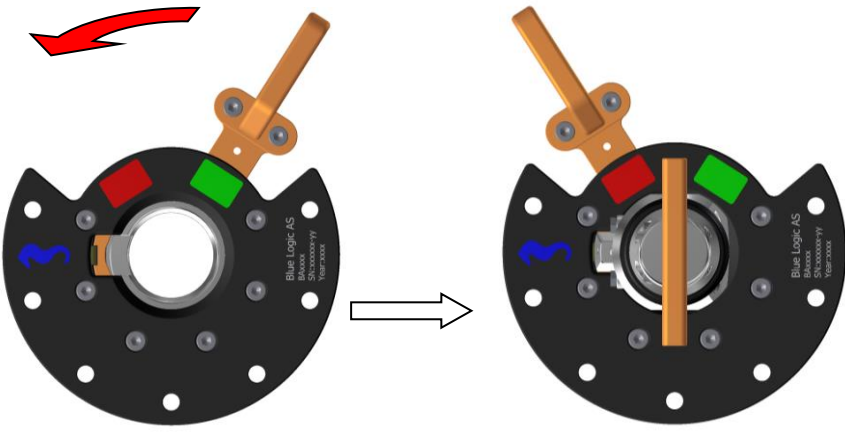

OPERATION AND MAINTENANCE MANUAL

No.	Description	Chk/Verified
05	<p>Operate Receptacle ROV/Diver handle from CLOSED (Green Position) COUNTERCLOCKWISE to OPEN position stab system.</p>  <p>Closed Position (Stab free for insertion)</p> <p>Open Position (Stab locked into receptacle)</p> <p>Note: It is always recommended to open or close without pressure and flow over the Valve Stab™ system.</p>	
06	<p>Verify hydraulic ports open and inspect Receptacle/ Stab for leakages. Operate desired hydraulic functions.</p>	



# OPERATION AND MAINTENANCE MANUAL

## 5.4. SUBSEA DISCONNECTION

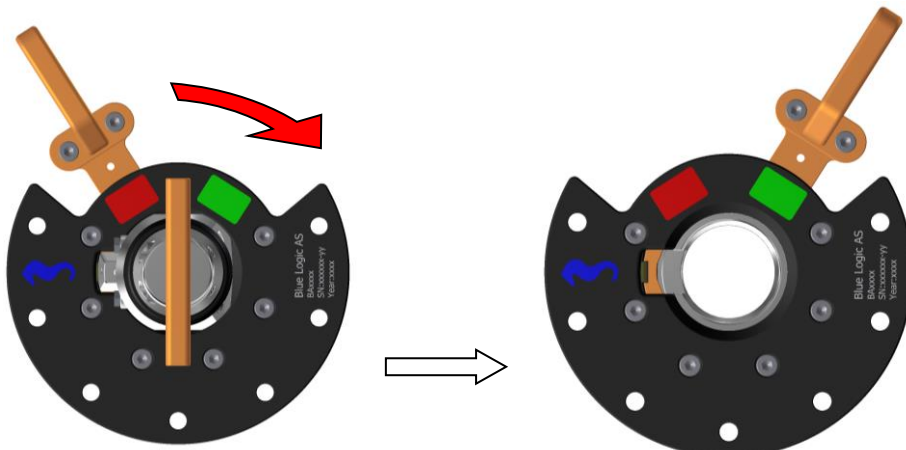
No.	Description	Chk/Verified
01	Visually inspect <b>Valve Stab™</b> Receptacle prior to subsea disconnection. Verify ROV/ Diver access and general condition of the <b>Valve Stab™</b> Receptacle in front of, and behind the panel.	
02	Close the <b>Valve Stab™</b> System Valve function by operating the ROV/ Diver handle <b>CLOCKWISE</b> .   <p>Open Position (Stab Locked in Receptacle)</p> <p>Closed Position (Stab free for removal)</p> <p>Note: It is always recommended to open or close without pressure and flow over the <b>Valve Stab™</b> system.</p>	
03	Pull the <b>Valve Stab™</b> out from the receptacle. Verify no leakages and perform a visual inspection.	
04	Continue with operation.	

### 5.5. POST DIVE CHECK

No.	Description	Chk/Verified
01	Recover Valve Stab™ equipment to deck.	
02	Perform a visual inspection  Seals Seal areas ROV Handle Flex Joint Hoses and piping Fittings Surface treatment	
03	Flush all equipment with fresh water	
04	Dry off equipment and apply protective oil prior to storage	

## 6. MAINTENANCE

### 6.1. GENERAL

The Valve Stab™ system is a simple and robust Subsea connection system with few critical moving parts. If moving parts is not filled with salt and sand/ debris but cleaned and lubricated, the only parts which will need to be routinely replaced is the seal system.

There are however a few important inspections points which shall be performed routinely to guarantee problem free use and operation of the Valve Stab™ System.

- MOB/Demob inspection and control
- Daily inspection during offshore operations
- Weekly routinely inspection during offshore operations
- Yearly inspection and maintenance

It is recommended to return the Valve Stab™ System to Blue Logic for a yearly inspection and maintenance to ensure minimum 20years of problem free use.

For MOB/demob, please see above Section 4.1.1

For Daily inspection during offshore operations; please see above Section 5.2 for pre-dive activities and Section 5.5 for post dive.

6.2. WEEKLY MAINTENANCE

No.	Description	Chk/Verified
01	Perform a visual inspection of Stab and receptacle. Inspect Surface treatment and verify no corrosion issues. Special attention should be to the following: <ul style="list-style-type: none"> <li>- Seals</li> <li>- Seal areas</li> <li>- ROV Handle</li> <li>- Flex Joint</li> <li>- Hoses and piping</li> <li>- Fittings</li> <li>- Surface treatment</li> <li>- Stab Guide Bracket</li> <li>- Receptacle Orientation Groove</li> </ul>	
02	Insert the <b>Valve Stab™</b> into receptacle. Verify correct engagement of orientation groove, guide bracket and Indicator Pin.	
03	Operate the <b>Valve Stab™</b> valve function by use of the ROV/Diver handle. Verify smooth movement.	
04	Close the <b>Valve Stab™</b> valve function, verify smooth movement.	
05	Pull the <b>Valve Stab™</b> out of the receptacle and verify that the valve function cannot be operated on either the Receptacle or Stab.	
06	Ensure protective oil applied and no water/moisture entrapped on critical parts.	
07	Operate in dedicated aluminum transport box.	

6.3. MONTHLY MAINTENANCE

No special activities are required on a monthly basis. If the **Valve Stab™** system has been extensively used and repeatedly exposed to dirt and aggressive fluids, all stabber and receptacle seals should be inspected and replaced if required.





## OPERATION AND MAINTENANCE MANUAL

### 6.4. YEARLY MAINTENANCE

It is recommended to return the equipment on a yearly basis to Blue Logic for full inspection, maintenance, and testing. In addition to the below listed actions, the cartridges will be disassembled and inspected, and cartridge seals replaced.

No.	Description	Chk/Verified
01	Inspect all external <b>Valve Stab™</b> Seals. Replace if required.	
02	Inspect all internal seal-surfaces in the Receptacle for scratches and/or damages.	
03	Check all mechanical functions, verify smooth operations. Inspect for scratches and general wear, lubricate all moving parts.	
04	Function test Stab and Receptacle and perform a full leakage test.	

### 6.5. SEAL REPLACEMENT

If replacement of cartridge seals for stab/receptacle is found required, the equipment must be returned to Blue Logic Service Department for replacement.

Replacement of the outer seals for the stab is feasible to perform in-field as described in the below section.

#### 6.5.1. Main Outer Seal (Stab)

Sequence for replacement of the Main Outer Stab Seals:

No.	Description	Chk/Verified
01	Remove old seals by use of a sharp knife. Cut the seals, make sure not to damage seal surfaces.	
02	Heat the new seals to 80-100 degrees using hot water.	
03	Stretch the new seals gently by hand. Slide the seals over the outer stab body. Use water or oil to lubricate.	

As an option, a dedicated Seal Replacement Tool is available. Please contact Blue Logic for further details.



# OPERATION AND MAINTENANCE MANUAL

## 7. STORAGE AND TRANSPORT

### 7.1. STORAGE

#### 7.1.1. Preservation for Storage

Prior to storage equipment must be thoroughly cleaned and visually inspected for any damages and wear. If any damages or wear in critically areas are discovered please contact Blue Logic for assessment.

It is critical that this is done, **Blue Logic's** experience is that failure to follow post-operation and storage -check lists is the main reason for service costs!

No.	Description	Chk/Verified
01	Ensure correct post dive sequence followed (see above sections)	
02	Make sure equipment is thoroughly flushed and cleaned (external and internal). This should have been done post dive/operation.	
03	Visual inspect the Hot Stab for damages and wear. Contact Blue Logic for assessment if any	
04	Apply preservation fluid and secure in storage box in a way that all seals and seal areas are protected	

### 7.2. TRANSPORT

No special precautions are needed for transport. However, the following should be verified:

Correct packing; preferably by use of aluminum transport box

Verify the following:

1. Sender Name and Address clearly visible
2. Receiver Name and address clearly visible
3. Inventory list correct filled out